

# PRODUCT RANGE

## SLEEPER INSTALLATION GUIDE

### TYPICAL SLEEPER ARRANGEMENT

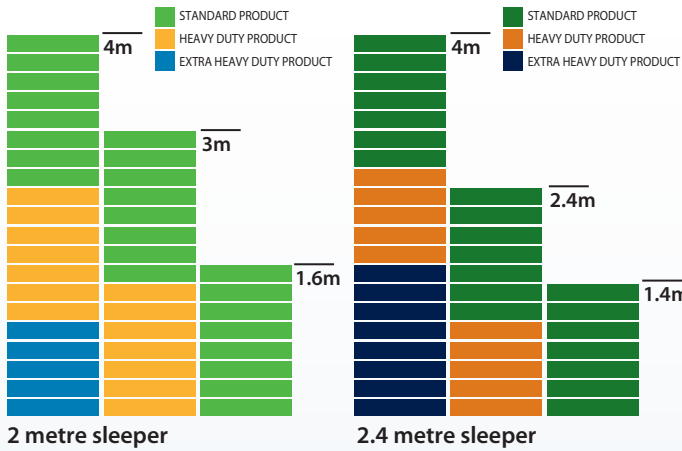

### 1 STRING LINE

Set pegs at each end of the retaining wall site and connect with a string line to give the required alignment. Holes should be dug at **2015mm** centres for 2.0m sleepers and **2415mm** centres for 2.4m sleepers.

A similar allowance of 15mm can be used for other lengths. Hole diameter must be at least **450mm** for a one metre high retaining wall. If your wall is over one metre high you will need council permission and engineers advice.

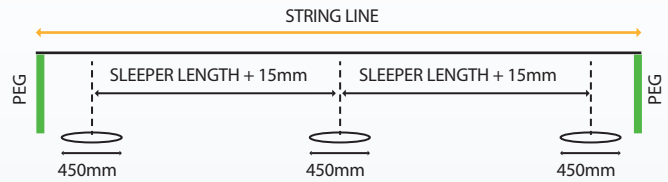

### 2 POST HOLES

The post holes for a typical 1.0m high wall must be dug at minimum **1100mm** deep, and **450mm** in diameter.

For higher walls, and where permits and council regulations apply, holes will typically be larger, please check with relevant authorities.

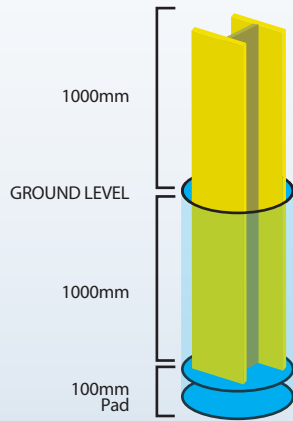

### 3 STEEL PLACEMENT

Place steel into recommended size hole, and set at 15mm longer than the sleeper being installed. For example, if you are using a 2.0m sleeper then space the steel uprights at 2015mm inside the channels. Timber props are a good idea at this stage to ensure correct spacing of steel. Ensure the steel is square and straight using level or laser. Once steel is in place, pour concrete into hole ensuring it is covered on all sides and underneath steel by at least 100mm. **DO NOT OVER FILL HOLES.** Typically concrete should finish at least 10mm below base of bottom of sleeper.

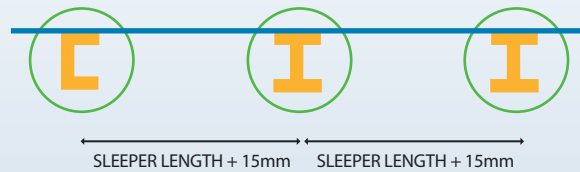

### 4 SLEEPERS

After the concrete has cured, place first sleeper between steel posts.

Use packing to adjust level, ensuring each layer is the same distance down from top of steel posts. It is good practice to insert wedges behind each sleeper to guarantee each is held to the front of the steel post.

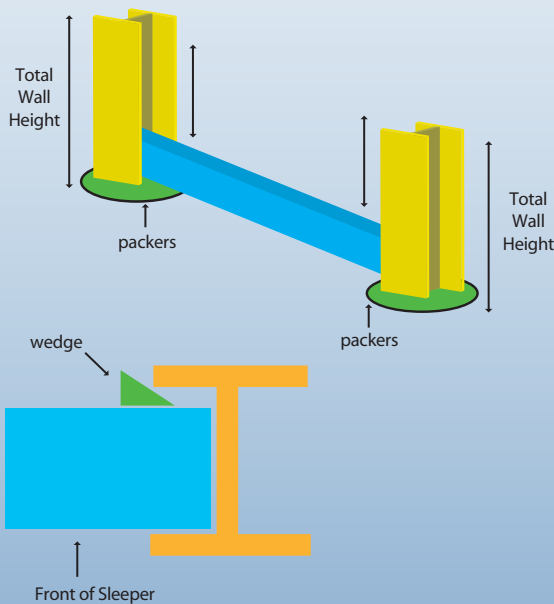

### 5 DRAINAGE

Once sleepers have been installed, place plastic membrane behind wall and slotted drain along length running to a discharge point. Cover drain and backfill with 20mm scoria up the height of the wall. Ensure there is no compaction behind wall to a distance of 75% of wall height.

Example, if your wall is 800mm high, then no compaction within 600mm of back edge of wall.

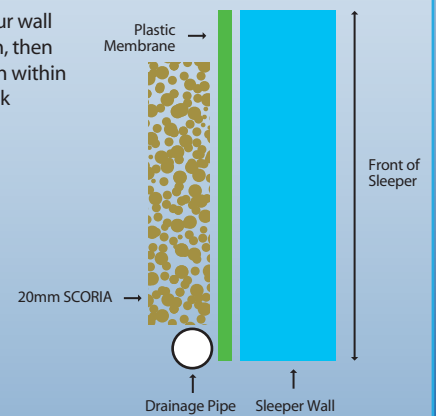

Note: Please ensure that during installation no equipment is driven over the wall backfill within 75% of the wall height. Compaction if any, within this area should be with non vibrating hand equipment weighing no more than 500kg per square metre of footprint. If greater compaction is required please obtain engineering advice. Wall designs shown are for 'typical' soil conditions. Calculations are available on our website. For walls over 1 metre you should seek independent engineering advice based on your specific site conditions.